

GEN-PACK 9.5 kVA



The Advantages

- very compact design, no bearing, no clutch
- short in length, compared with standard designs, by a factor 2 shorter.
- excellent handcrank starting capability
- reliable and robust design
- not even one single part affected by mechanical wear
- no rotating coils
- no rotating electronic parts
- no brushes, no slip rings
- no sensitive voltage regulator
- extreme high efficiency above 92 % at 9.5 kVA
- completely closed alternator housing - cooling air circulation taken from engine side

Characteristics

The Electric Power Unit consists of a unique and solid alternator design and the well known HATZ single cylinder engine model 1 D 81 S SUPRA resulting in a very compact and short generator set.

The slots in the stator are of such dimension that additional windings are possible for starter motor purposes.

Adding a mechanical commutator where space is available the unit now acts as a starter motor for the diesel engine on a DC-motor system.

From approx. 400 r.p.m. the commutator is switched off by centrifugal force.

“Starting-in” into a running engine is simply not possible.

Characteristics of the mech. structure

- synchronous alternator with permanent magnet excitation
- stator with three-phase winding inside the rotor rigidly connected to the engine flywheel housing
- rotor bolted to the blower fan engine flywheel
- no bearing for the alternator at all
- no mechanical contact of rotating parts results in no mechanical wear
- solid and simple mechanical structure

Version with Electric Start

- the magnetic force results in a start up torque which is transmitted directly to the engine crank shaft
- there is neither a ringgear nor a starter motor pinion
- no expensive electric starter motor protection devices are necessary because there is no mechanical contact of rotating parts when engine is running..

Electrical Data

rated voltage	: 400 /231 V; 3~,N; 380 /220 V; 3~,N
rated output	: 9.5 kVA
frequency	: 50 Hz
speed	: 3000 r.p.m.
rated current	: 14,5 A
power factor $\cos \varphi_N$: 0.9 ind
degree of protection	: min. IP 34
voltage accuracy	: + / - 10 % to DIN ISO 8528-5 Class G1
efficiency	: 92 %
isolating class	: F / H
frequency droop	: < 8 % according to DIN ISO 8528-5 performance class G1
steady-state frequency band	: < 2.5 % according to DIN ISO 8528-5 performance class G1

Permanent magnet alternator design

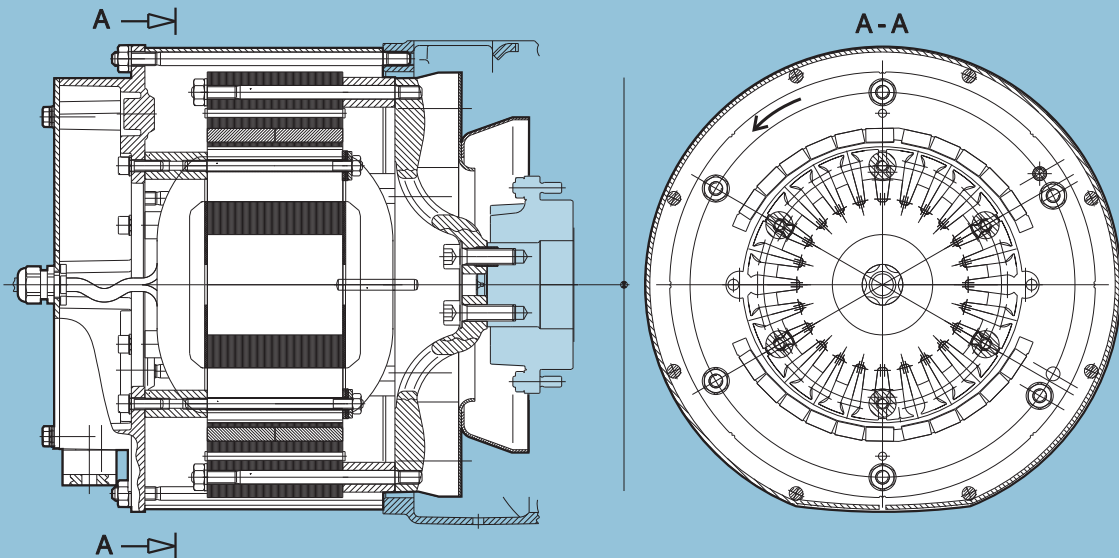

Dimensions

Spread at outlines ± 3 mm due to tolerance

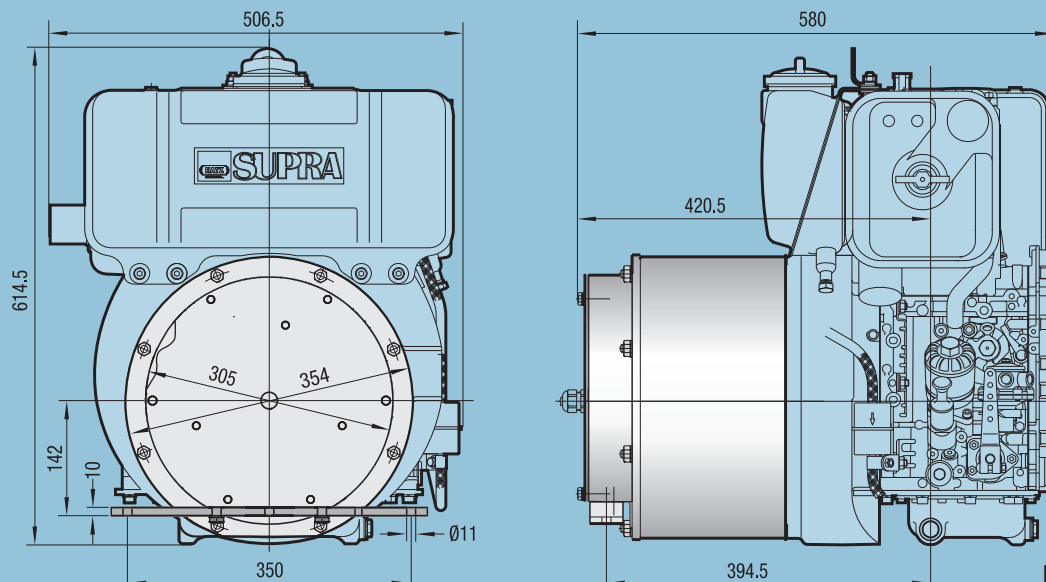

Engine 1D81.



MOTORENFABRIK HATZ
D-94099 RUHSTORF · GERMANY

Telephone: +49 (0) 85 31 / 319-0 · Telefax: +49 (0) 85 31 / 31 94 18
www.hatz-diesel.de · eMail: marketing@hatz-diesel.de

